

QUICK START

If you are familiar with real time analyzers, feel free to jump right in. To avoid some of the lurking sharks read these few tips as a reminder of what it is you already know:

FLAT IS NOT BEAUTIFUL. Equalizers have two basic purposes: correction and enhancement. The Rane analyzer allows you to accurately correct system response to each location. A task very difficult to do by ear. Once this is quickly done, then you adjust for further sound quality enhancement by ear; only rarely will a system be left in a “flat” condition.

USE MORE THAN ONE TEST MICROPHONE LOCATION. Speaker dispersion characteristics vary greatly, from beamy highs to boomy bass traps. While performing the pink noise test, try at least two different test mic locations and average the two if they differ.

USE ENOUGH PINK NOISE VOLUME TO OVERRIDE BACKGROUND NOISE. There’s no need to run deafening pink noise levels to EQ a system. Just be sure that no green/red LED responds when pink noise is turned off (if they do, background noise is causing erroneous readings and pink noise should be turned up higher).

USE ± 3 dB DISPLAY SETTING FOR LOW FREQUENCY ADJUSTMENTS. The crest factor (peak response) of true pink noise causes considerable LED flutter in the ± 1 dB mode, making it difficult to adjust quickly. We recommend that the ± 3 dB setting be used on frequencies below 500 Hz or so; use the ± 1 dB on the more sensitive mids and highs.

MONITORING PROGRAM WITH ANALYZER DISPLAY. When the front panel microphone is unplugged, the analyzer display automatically monitors the RA 27 LINE INPUT signal. Use this feature to identify specific feedback points by watching for red LEDs during the performance. You can then apply EQ exactly where it’s needed very quickly. If all else fails, read the rest of the manual.

FRONT PANEL DESCRIPTION

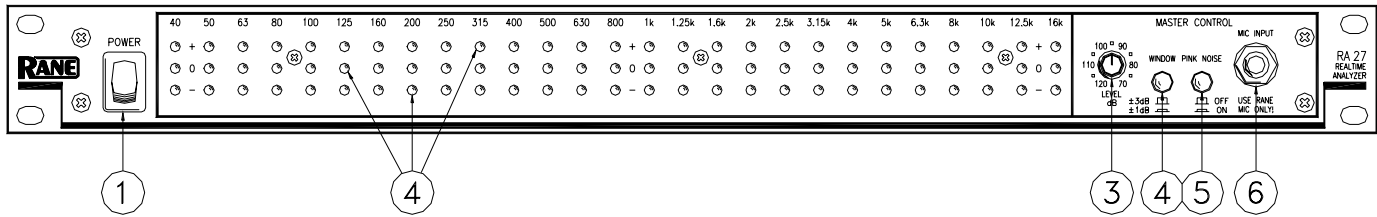

- ① **POWER switch:** You've probably figured this one out by now...
- ② **Analyzer display LEDs:** Each red LED lights up when response is too high in that band; green LEDs light when response is within ± 3 dB or ± 1 dB of the selected curve; yellow LEDs come on when response is too low.
- ③ **LEVEL control:** Use this knob to adjust the microphone level (or line level when the microphone is unplugged) to properly drive the display. This control is accurately calibrated in dB-SPL; any display band whose LED is green has the sound pressure level indicated by this knob (*only with the mic plugged in*).
- ④ **WINDOW switch:** In the ± 3 dB position, the green LED in each band lights when signals of that frequency are within 3 dB above or below the Normal or House curve, whichever is selected. In the ± 1 dB mode, system response must be within 1 dB above or below the selected curve to light the green LEDs.
- ⑤ **PINK NOISE switch:** Engage to activate the built-in pink noise generator. *Be sure your system is turned down before engaging this switch to prevent scaring yourself.*
- ⑥ **MICROPHONE INPUT jack:** PLUG ONLY THE RANE MICROPHONE INTO THIS JACK – THE DC VOLTAGE SUPPLIED BY THIS JACK COULD BE DAMAGING TO ANY OTHER MICROPHONE. When the mic is plugged in, the display responds to whatever the mic picks up; when the mic is unplugged, *the MIC INPUT jack automatically switches the display to monitor the LINE INPUT jack signal on the rear.*

REAR PANEL DESCRIPTION

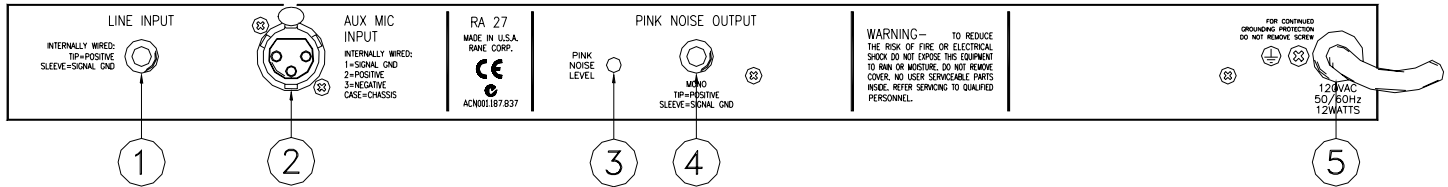

- ① **LINE INPUT jack:** This is an unbalanced 1/4" Input to the analyzer. The range of acceptable signal levels is 15 mV-3.0 V
- ② **AUX MIC INPUT jack:** A female XLR type connector for inserting signals from a low impedance microphone into the RA 27. Use this jack when you wish to use a microphone other than the one supplied.
- ③ **PINK NOISE LEVEL adjust:** Use a 1/8" screwdriver to adjust the output from the Pink Noise generator from 0 to 1.2 volts (+4 dBu) to match the input level requirements of the mixer or other equipment.
- ④ **PINK NOISE OUTPUT jack:** This is an unbalanced 1/4" jack which supplies Pink Noise to the sound system.

RA 27 CONNECTION

SYSTEM HOOK-UP

Connect the RA 27 into your system as shown below. Plug the Rane condenser microphone into the front panel MIC INPUT. *CAUTION: Do not plug any other microphone into the front panel jack: This jack contains DC voltage which may be damaging to other microphones.* For special applications you can use another microphone by patching into a send/receive loop on a mixer as described in Rane Note 104 (available on from our website or by mail request).

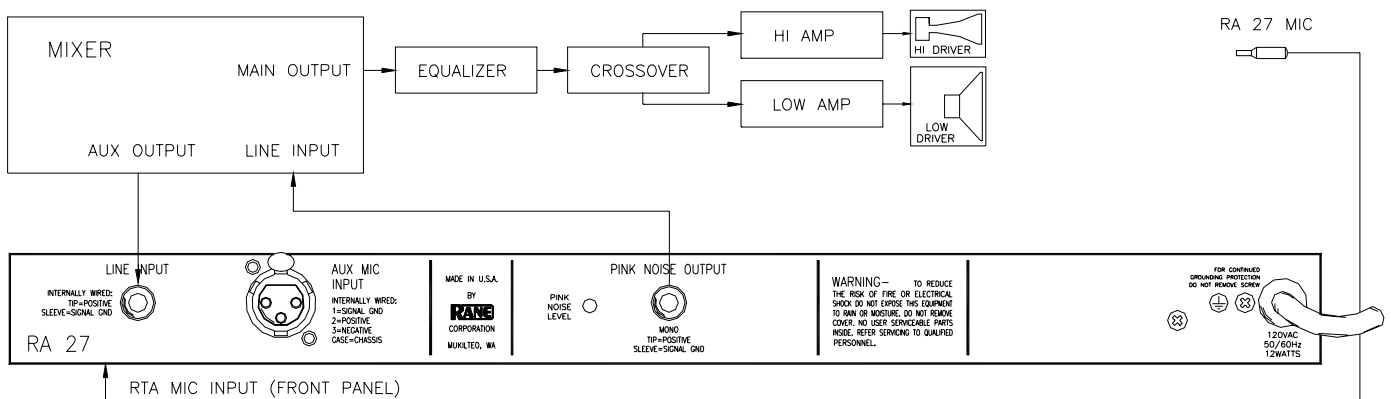

OPERATING INSTRUCTIONS

Since the RA 27 features a unique form of realtime analyzer, we highly recommend that you read this section before performing an alignment with pink noise. If you've never used an analyzer before, use these instructions on your first occasion. You'll be delighted at how simple it really is.

BACKGROUND NOISE CHECK

Any background noises such as air conditioners, talking, wild animals, traffic and the like can cause false readings on the analyzer display if the pink noise volume through the speakers is not loud enough to drown these noises out. Before turning on the Pink Noise, turn up the LEVEL control on the RA 27 until some of the green and red LEDs respond on the display: now you're looking at background noise. Slowly turn the LEVEL control back counter-clockwise until all the green and red LEDs are off, and no background noise is showing on the display. You will now have to run the pink noise volume through the speakers loud enough to make sure that the LEVEL control is not turned clockwise (up) from this setting, otherwise the background noise will falsify the readings.

PINK NOISE RUN-UP

Turn down the mixer output controls *before* switching on the Pink Noise, so that you don't detonate your speaker cabinets. Now switch the PINK NOISE button *ON* on the RA 27 and turn up the mixer and EQ LEVEL controls slowly until you hear pink noise through the speaker(s). There is a Pink Noise Output Level Adjustment on the rear of the RA27 – use a 1/8" screwdriver to vary the amount of Pink Noise to the mixer if necessary.

MICROPHONE PLACEMENT

You should perform the pink noise test with at least *two different test microphone locations* for each separate channel of EQ. Since speaker dispersion characteristics can vary greatly, it is desirable to look at a couple of different areas with the mic to obtain an average for the entire listening area. If you are using one equalizer channel for both speakers (mono), place the mic in the center of the left half of the listening area and adjust for green LEDs with pink noise through the left speaker. Now move the mic to the center of the right half of the listening area, run pink noise through the right speaker and observe the analyzer LEDs: use the RA 27 LEVEL control to center the response for as many green LEDs lit as possible. For each frequency that requires a different adjustment than the left channel, note the original setting of the slider, then adjust it so that the green LED above it is lit and then note this new slider position: the final setting should be half-way between these two slider positions, resulting in an average response for the left and right channels. If you are running stereo, use two mic locations for each channel, averaging in the same manner if there are differences. Analyze one channel at a time.

ANALYZER SETTINGS

Select either the ± 3 dB or the ± 1 dB WINDOW on the analyzer. We recommend starting with the ± 3 dB setting, then switching to the ± 1 dB mode for fine-tuning frequencies above 400 or 500 Hz. The crest factor (peak response) of true pink noise causes considerable LED flutter in the ± 1 dB mode below about 500 Hz, thus it is expedient to use the ± 3 dB setting for these frequencies.

INITIAL SYSTEM ALIGNMENT

Before using the equalizer for adjustment, use the analyzer to align other equipment in the system (EQ should always be a *last* resort after you've corrected response problems everywhere else). With all EQ sliders flat (centered) adjust the electronic crossover frequencies and level controls (if used), passive crossover controls, speaker placement and alignment, etc. to get as many green LEDs lit as possible on the display. Only after this is done should you use the equalizer sliders to flatten the system (see next step).

EQUALIZER SLIDER ADJUSTMENTS

Now adjust each slider up or down as necessary until the green LED corresponding to the same frequency is lit; if the red is lit, move the slider down until green comes on. If yellow is lit, move the slider up to obtain green.

If you can't get one or more green LEDs lit with their sliders fully boosted or cut, make a slight adjustment in the Pink Noise volume or LEVEL control to get these bands in the green. Then re-adjust the remaining sliders. You will also notice that adjusting one slider may affect the LED readings on the adjacent bands: this is due to the presence of frequencies half-way between the two bands, which will be affected by both sliders. Not to worry: simply nudge the adjacent slider until the green LED lights up again.

FINAL EQUALIZER ADJUSTMENTS

Once the RA27 is all "greened out", you're done with the pink noise alignment test. Now the speakers are properly coupled to the specific room and the overall system response is accurately aligned. This alone will make a great improvement in most systems, *but don't stop at flat* necessarily. Now that the RA 27 has given you a consistent starting point, feel free to make further slider adjustments during the performance or sound check to enhance overall sound quality. Fatten the bass, smoothen the mids or sweeten the highs to taste. You will probably find that these adjustments will be consistently set above or below the Pink Noise test settings the same amount at each performance; make a note of these further adjustments to save future tweaking during performances. For example, you note the pink noise settings and find later that you like to have 3 dB more boost at 63 Hz for more low-end punch during the performance. Next time, green out the analyzer during the pink noise test (get all LEDs green before making any further adjustment), then immediately bump up the 63 Hz slider 3 dB as indicated by the front panel calibrations so that you're tuned up before the show starts (slick, no?).

MONITORING PROGRAM MATERIAL FOR FEEDBACK USING THE DISPLAY

Once the pink noise test is completed, switch off the PINK NOISE on the RA 27 and unplug the Rane test mic from the front panel jack. When the mic is unplugged, the display is automatically switched to monitor the signal at the RA 27 LINE INPUT jack on the rear. Adjust the LEVEL control so that an occasional green LED blinks on during the performance peaks, but no red LEDs come on: you should be in the ± 3 dB mode on the display. If feedback occurs, one or more red lights show the general feedback frequency area. Usually several red LEDs will be lit by the time you quickly cut back volume to kill the feedback and glance at the display. When this happens *keep watching the display*: the last red LED to go off contains the exact feedback frequency (it was the first LED on, too, but you probably didn't see it). Adjust that slider down a couple dB and feedback problem will be reduced. If you're real good you'll keep one eye on the analyzer display and quickly adjust one or two sliders when feedback occurs, without altering master volume levels. This program monitoring feature is particularly useful for stage monitors which are usually plagued with feedback problems.

TESTING

The RA 27 really contains its own test equipment. By patching the PINK NOISE OUTPUT to the LINE INPUT with a mono 1/4" patch cord (and no mike plugged in) the entire analyzer/pink noise system can be checked and verified. Turn up the LEVEL control until the display LEDs respond. With all sliders centered, the display should show all green in the ± 3 dB position with proper level settings. Switching to ± 1 dB should show mostly green with some LED flutter in the lower frequency bands below 1 kHz (due to inherent crest factor of pink noise showing through the 2 dB window).

MAIN SPEAKER EQUALIZATION

IMPORTANT NOTES:

1. If your sound system is stereo or multichannel, equalize each channel individually first, then look at the combined acoustic output of all channels, making small corrections as necessary.
2. If you are using a powered mixer, or a mixer that has mic level inputs only, you will need to reduce the signal level at the pink noise output. Use a small screwdriver to adjust the PINK NOISE LEVEL control on the rear chassis so the Pink Noise Output suits your mixer.
3. An RA 27 can be used as a driver alignment tool (see the AC 22/23/B Owners Manual) as well as a room-flattening equalizer. Drivers are aligned when maximum level is shown at the crossover frequency on the RA 27 display. It is important to align drivers either physically or electronically in multi-way systems for the best sound. The mic should be at listener-ear height relative to the center of the driver stack. If a clear sound is desired in the back of the hall, the height of the RA 27 mic should be in line with the on-axis phase response of the speaker stack, perpendicular to the drivers.

STAGE MONITOR EQUALIZATION

IMPORTANT NOTES:

1. Analyzing and equalizing the monitors provides the most expedient method to optimize stage monitor sound quality and reduce feedback problems. The stage mic is connected to the same mixer as the RA 27. Feedback induced by specific stage mic/monitor speaker coupling can also be attenuated by leaving the stage mic turned up and running up the pink noise level through the monitor speaker until feedback occurs. Attenuate each feedback frequency, as indicated by the analyzer display, until the mic/monitor combination feeds back at two or more frequencies simultaneously. Usually the final EQ setting will be a compromise between a good monitor sound that doesn't get as loud, or a not-so-good monitor sound that gets louder before feedback.
2. Place the Rane microphone at eye level of the performer and about six inches off to one side of the stage microphone, in line of sight to the monitor speaker. If the stage microphone is directly between the Rane mic and monitor speaker (blocking line of sight), some high frequencies will be blocked giving a false reading on the analyzer display.
3. If you are running more than one monitor from a single equalizer, test each monitor location by running up pink noise until feedback occurs. The monitor which feeds back soonest should be used for the overall EQ adjustments using pink noise.
4. If maximum SPL before feedback is most important, use the stage mic only. This arrangement allows the analyzer to look at the specific relationship between each stage microphone/speaker combination. Since both the microphone and stage monitor speaker exhibit their own individual feedback tendencies, the interaction between the two can cause pronounced feedback problems. This configuration allows you to flatten or "normalize" this interaction without actually getting to feedback levels. It should be noted that *this testing procedure favors maximum SPL before feedback and not necessarily optimum monitor sound quality*. This configuration can also be used for main speaker equalization to optimize system response for a specific microphone used throughout the system, such as for choir, orchestral or big band situations where all program material is picked up through microphones of the same make and model.
5. Do not attempt to plug a regular microphone directly into the MIC INPUT. See Rane Note 104 regarding use of other microphones with the RA 27.